



8600 N.W 70th Street
Miami, FL 33166 Ph #
305-343-0008 Fx #
305-477-0690
deeb@vemaco.com
www.vemaco.com

TR ENGINES

TR1, TR2, TR3

Power ranges: 5.5-28.5 kW; 7.4-38.0 bhp

Variable or fixed speed; full load speed range: 1500-2500 r/min

RELIABLE, DURABLE HEAVY DUTY AIR COOLED DIESEL ENGINES

SPECIAL ATTRIBUTES

- variable and fixed-speed builds available
- designed for continuous operation in ambient temperatures up to 52°C (122°F)
- oil cooling by means of air flow over deep crankcase finning

BASIC ENGINE CHARACTERISTICS

- diesel fuelled
- direct injection
- 1, 2 or 3 cylinders
- air cooled
- naturally aspirated
- handstart (electric optional)

DESIGN FEATURES AND EQUIPMENT

- air cleaner
- inlet and exhaust manifolds
- self vent fuel system with individual fuel injection pumps
- fuel filter
- self regulating plunger type lubricating oil pump
- spin-on lubricating oil filter
- decompressor levers
- flywheel
- flywheel housing with SAE4 flange
- 250 hour service intervals
- mechanical governing:
 - variable speed 900-2500 r/min
 - fixed speed 1500 and 1800 r/min
- operators' handbook



TR ENGINE

EMISSIONS

- models under 19kW comply with EU Stage 3A exhaust emissions regulations

OPTIONAL ITEMS

- 12V electric start
- gear case power take-off (see over)

POWER OUTPUTS ¹ TO ISO 3046						
Variable Speed		r/min	1500*	1800*	2000	2500
TR1	Continuous Power	kW	5.5	6.7	7.3	8.6
		bhp	7.4	9.0	9.8	11.5
	Fuel Stop	kW	6.1	7.4	8.0	9.5
		bhp	8.2	9.9	10.7	12.7
TR2	Continuous Power	kW	11.0	13.1	14.5	17.3
		bhp	14.8	17.6	19.4	23.2
	Fuel Stop	kW	12.1	14.4	16.0	19.0
		bhp	16.2	19.3	21.5	25.5
TR3	Continuous Power	kW	16.8	20.2	22.2	25.9
		bhp	22.5	27.1	29.8	34.7
	Fuel Stop	kW	18.5	22.2	24.4	28.5
		bhp	24.8	29.8	32.7	38.2

* For fixed speed engines the powers at these speeds are the same.

Notes:

1. Power ratings (measured at the flywheel) and fuel consumptions, apply to a fully run-in, non-derated engine without power absorbing accessories or transmission equipment.
2. The overload capability applies to a fully run-in engine. This is normally attained after a running period of about 50 hours.

TORQUE TO ISO 3046						
Variable Speed		r/min	1500	1800	2000	2500
TR1	Fuel Stop	Nm	38.8	39.2	38.2	36.3
		lbf ft	28.6	28.9	28.2	26.8
TR2		Nm	77.0	76.4	76.4	72.6
		lbf ft	56.8	56.3	56.3	53.5
TR3		Nm	117.8	117.8	116.5	108.9
		lbf ft	86.9	86.9	85.9	80.3

RATING DEFINITIONS, TO ISO 3046

ISO Standard Conditions

Barometric pressure	100 kPa
Relative humidity	30%
Ambient temperature at air inlet manifold	25°C

1. Fixed speed power: continuous power (ICN)

The power in kW which the engine is capable of delivering continuously at the stated crankshaft speed, under ISO standard conditions, measured at the flywheel without power-absorbing accessories, provided that the engine is overhauled and maintained in good operating condition and that fuel to BS EN 590 Class A1 or A2, and lubricating oils to the correct performance specification and viscosity classification as recommended by Lister Petter Limited, are used.

2. Fixed speed power: overload power (ICXN)

The maximum power in kW which the engine is capable of delivering intermittently at the stated crankshaft speed for a period not exceeding one hour in any period of twelve hours' continuous running, immediately after working at the continuous power, under ISO standard conditions and with the provisions specified in (1) above.

3. Variable speed: fuel-stop power, continuous power (IFN)

The maximum power in kW which an engine is capable of delivering continuously at stated crankshaft speed, under ISO standard conditions and with the provisions specified in (1) above, with the fuel limited so that the fuel stop power cannot be exceeded.

4. Variable speed: fuel-stop power, intermittent power (IOFN)

The maximum power in kW which an engine is capable of delivering intermittently at the stated crankshaft speed, for a period not exceeding one hour in any period of twelve hours' continuous running, with the fuel limited so that the fuel stop power cannot be exceeded, immediately after running at the rating in (3) above, under ISO standard conditions and with the provisions specified in (1) above.

5. De-rating

For non-standard site conditions, reference should be made to relevant BS, ISO and DIN standards.

The overload capability applies to a fully run-in engine. This is normally attained after a running period of about 50 hours.

Key to Emissions Compliance

EU Stage 3A only	
------------------	--

TECHNICAL DATA				
		TR1	TR2	TR3
Type of fuel injection		Direct	Direct	Direct
Number of cylinders		1	2	3
Aspiration		Natural		
Direction of rotation looking on flywheel end		Anti clockwise		
Nominal cylinder bore	mm	98.42	98.42	98.42
	in	3.875	3.875	3.875
Stroke	mm	101.6	101.6	101.6
	in	4.0	4.0	4.0
Total cylinder capacity	litre	0.773	1.55	2.32
	in ³	47.17	94.35	141.52
Compression ratio		15.5:1	15.5:1	15.5:1
Minimum idling speed	r/min	850	850	850
Number of flywheel ring gear teeth		110	110	110
Crankshaft end thrust (maximum continuous)	kgf	132	132	132
	lbf	290	290	290
Crankcase vacuum (minimum)	mbar	2.0	2.5	3.0
	in H ₂ O	0.8	1.0	1.2
Crankcase vacuum (average)	mbar	3.5	4.6	7.5
	in H ₂ O	1.4	1.8	2.9
Lubricating oil pressure (mean) with the oil at 110°C (230°F)	bar	2.0	2.0	2.0
	lbf ft ²	29	29	29
Lubricating oil pressure at idle	bar	1.0	1.0	1.0
	lbf ft ²	14.5	14.5	14.5

FUEL CONSUMPTION									
The 100% load figures are subject to 5% tolerance but all other figures are approximate and not guaranteed.									
Variable Speed		100% Load, Continuous Power				75% Load, Continuous Power			
r/min		1500	1800	2000	2500	1500	1800	2000	2500
TR1	litre/hr	1.5	1.9	2.1	2.5	1.2	1.5	1.6	2.0
	US gal/hr	0.4	0.49	0.55	0.67	0.31	0.39	0.43	0.53
TR2	litre/hr	3.1	3.7	4.1	4.9	2.4	2.9	3.2	3.8
	US gal/hr	0.81	0.97	1.07	1.3	0.64	0.76	0.85	1.03
TR3	litre/hr	4.6	5.5	6.1	7.3	3.6	4.3	4.7	5.7
	US gal/hr	1.21	1.46	1.60	1.91	0.96	1.15	1.26	1.51

APPROXIMATE DIMENSIONS AND WEIGHT

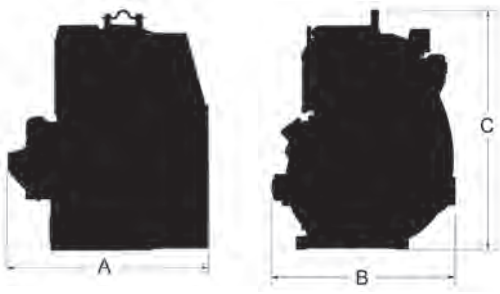
		TR1	TR2	TR3	
	Dry weight	kg	153	185	230
		lb	337	408	507
	Length (A) without fuel tank	mm	444	571	698
		in	17.5	22.5	27.5
	Width (B)	mm	521	521	521
		in	20.5	20.5	20.5
	Height (C)	mm	683	683	683
		in	26.9	26.9	26.9

A range of options allows you to select a specification that matches your requirements, please consult your Lister Petter Power Systems distributor.



8600 N.W 70th Street
 Miami, FL 33166
 Ph # 305-343-0008
 Fx # 305-477-0690
 deeb@vemaco.com
 www.vemaco.com



Lister Petter have made efforts to ensure that the information in this data sheet is accurate but reserve the right to amend specifications and information without notice and without obligation or liability.